

Description

The Clean Comfort™ High-Efficiency Return Grille-Mount Electronic Air Cleaner for residential applications helps remove a wide range of airborne particles as small as 0.06 micron (1/424,000 of an inch).

- Helps protect and prolong the operating efficiency of the heating and cooling equipment
- Features a permanent, washable filter system
- Designed for homes, condominiums, manufactured homes, and applications where there is a common return grille rather than separate return air ducts from each room
- An excellent choice for homes with attic or crawl space heating and air conditioning installations
- Easily installs on the wall or ceiling in a ceiling box within trusses on 24- inch centers without any structural changes

Standard Features

- Aluminum mesh prefilters (2) prevent lint and large particles from entering collecting cells
- Heavy-gauge aluminum collecting cells (2)
- Plastic intake grille is easy to wipe clean
- Hinged, swing-out door
- Automatic interlock switch disconnects power when unit is opened
- Electronic air-proving switch (APS)
- Automatically cycles air cleaner on/off with the system fan
- Performance indicator light (green LED) indicates high voltage to the collecting cells, ensuring air cleaner is operating properly at a glance
- Solid-state power board is equipped with a variable resistor (potentiometer) to adjust high voltage output



* Warranty doesn't apply to Prefilter. Other exceptions apply. Complete warranty details available from your local dealer or at www.cleancomfort.com.

HIGH-EFFICIENCY RETURN GRILLE-MOUNT ELECTRONIC AIR CLEANER

MODEL

AE14-2025-51G



Accessories

DAX Air Cleaner Detergent for cleaning collecting cells.

Available in a 32 oz. (1 L) spray bottle

Part#

AEP-FS9900

Additional Information

Before purchasing this appliance, read important information about its estimated annual energy consumption, yearly operating cost, or energy efficiency rating that is available from your retailer

* Per ASHRAE 52.2-2007 test standard. Data available upon request.



TECHNICAL SUPPORT • 1-800-267-8305 • www.cleancomfort.com

Efficiency

The table to the right shows results from an independent testing laboratory that measured the particulate removal efficiency of the Clean Comfort™ Electronic Air Cleaner.

At rated airflow, the electronic air cleaner achieves a MERV 14 rating. With the fan running on low speed, the air cleaner increases efficiency up to a rating of MERV 16.

The static pressure drop of the electronic air cleaner is as low as 0.16" compared to 0.22" or higher for a typical 1" MERV 8 furnace filter.

Clean Comfort™ Electronic Air Cleaner

Particle Size	600 CFM	1000 CFM	1400 CFM
0.3-0.4	99.2	87.5	65.4
0.4-0.55	99.7	91.6	74.0
0.55-0.7	99.8	95.1	80.3
0.7-1.0	99.9	97.3	86.0
1.0-1.3	99.9	98.5	90.4
1.3-1.6	99.9	99.1	93.2
1.6-2.2	100.0	99.5	95.3
2.2-3.0	100.0	99.8	97.4
3.0-4.0	100.0	99.9	98.3
4.0-5.5	100.0	99.9	99.0
5.5-7.0	100.0	100.0	99.5
7.0-10.0	100.0	100.0	99.9

Data shown for AE14-1625-51

SPECIFICATIONS	
MODEL	AE14-2025-51G
House Size Area (typical)	Up to 4000 ft ² [372 m ²]
Airflow	Up to 2000 CFM [400 m ³ /hr]
Duct Size	22 x 29.1 in [55.9 x 73.9 cm]
Cabinet Dimensions	31.4 x 24.4 x 7 in [79.8 x 62 x 17.8 cm]
Unit Weight	38 lbs [17.5 kg]
Input Voltage	120 V 60 Hz
Power Consumption (when operating)	30 Watts

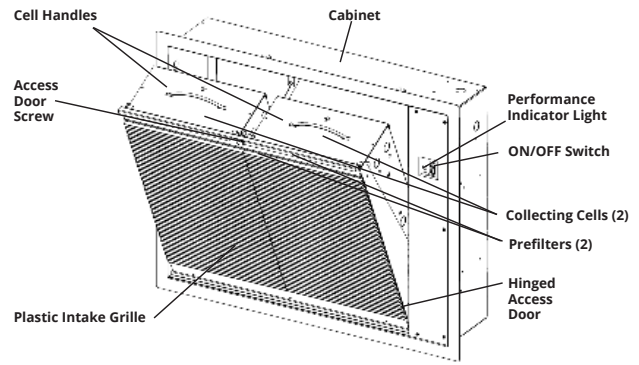

DIMENSIONS (inches)

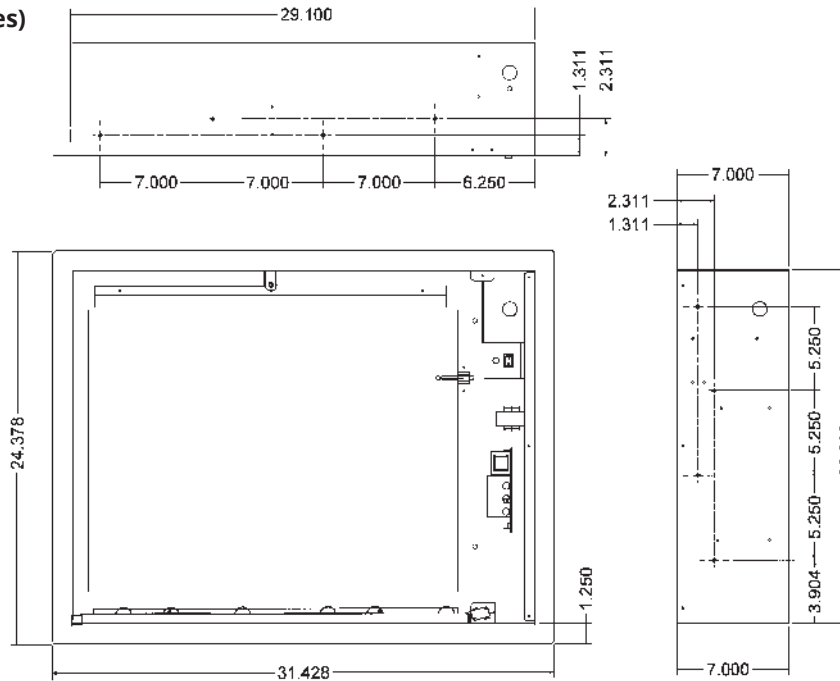

TECHNICAL SUPPORT • 1-800-267-8305 • www.cleancomfort.com

Our continuing commitment to quality products may mean a change in specifications without notice.
 © 2015 • DAIKIN NORTH AMERICA LLC • Houston, Texas • Printed in the USA.